

C-MORE

WORLD CHAMPION SIGHTS

Instruction Manual - CRC

SIGHT MODELS:

CRCB-4 Voice - 540-347-4683
 CRCB-6 Fax - 540-347-4684
 e-mail - sales@cmore.com
 web - www.cmore.com

Congratulations! You are now the owner of the most advanced reflex sighting system available. You have displayed excellent judgement in your purchase, and you will be rewarded with unparalleled performance. Use it with pride, but please familiarize yourself with the system first.

PACKAGE CONTENTS:

1 - CRC Sight
 1 - Sight Cover
 1 - CR2032 Battery
 1 - Adjustment Tool
 1 - Mounting Screw Pack
 1 - Cleaning Cloth
 1 - Instruction Manual

PLEASE read instructions before operating or installing this sighting system.

© C-MORE Systems 1993-2023

CMS-IB-CRC_2023-04-25



DESCRIPTION OF MAJOR COMPONENTS

INTENSITY SWITCH (UP and DOWN Buttons)

Used to turn the sight ON, adjust the intensity of the dot, and turn the sight OFF. The CRC provides 10 visible brightness settings, 5 Low Light and 5 Daylight.

Turning ON : Pressing the UP button will turn the dot on to the previously set intensity.

Adjusting Intensity: Pressing the UP button will adjust the intensity of the dot UP incrementally to position 10. Pressing the DOWN button will adjust the intensity of the dot DOWN incrementally to position 1.

Turning OFF: Holding the DOWN button for 3 seconds will turn the dot off.

Motion Sensing System (MSS): After 3 minutes with no motion or vibration, the sight will power down the Dot and enter standby mode to save battery life. Once any motion or vibration is detected, the sight will instantly power on the dot for immediate use. The CRC does not have an AUTO OFF mode and will remain in Stand By mode until manually powered down completely by holding the DOWN button for 3 seconds.

Low Battery Indicator: The dot will flash when the battery voltage cannot sustain the current intensity level. Lowering the intensity will allow further use until the battery voltage cannot sustain that intensity level.

ELEVATION SCREW

Used when zeroing weapon. Turning the elevation adjustment screw clockwise moves the point of impact down. Turning the elevation adjustment screw counter-clockwise moves the point of impact up. (1 click = 1moa)

WINDAGE SCREW

Used when zeroing weapon. Turning the windage adjustment screw clockwise moves the point of impact left. Turning the windage adjustment screw counter-clockwise moves the point of impact right. (1 click = 1moa)

STOP!! Make sure your firearm is unloaded and the magazine and ammunition has been removed before proceeding!

INSTALLATION INSTRUCTIONS

The CRC can be installed using a C-MORE mount or mounting kit, an aftermarket or custom mount, or directly to the firearm with the correct mounting interface machined into the slide or barrel depending on the firearm, or an Optic Ready plate system designed for this sight. The CRC sight utilizes the Shield mounting standard and the RMSc footprint, and will fit most optic ready firearms or mounts made for the Shield, Delta Point Pro, or JPoint sights. The CRC provides a variety of mounting screws for attaching to specific applications as well as generic standard length screws that can be trimmed to length.

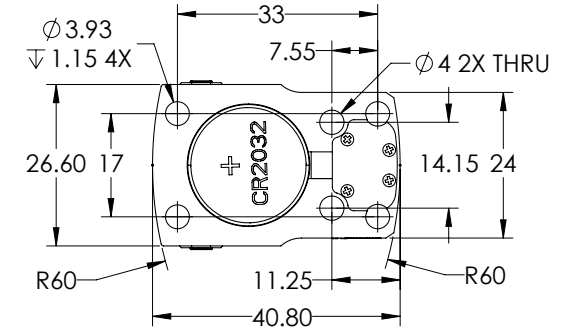

Battery Installation:

While holding the CRC upside down, install the CR 2032 battery as shown with the Positive side facing up by first inserting the battery against the front battery contact and pushing toward the front of the sight to depress the contact, then rotate the rear side of the battery down and use both thumbs to completely seat the battery flush into the battery compartment.



Installation Instructions:

The sight must be mounted on a flat surface that supports the entire footprint, length and width, of the sight. Follow the instructions provided with the mount or mounting kit, or utilize the direct mounting screws provided. Loctite should be used on the mounting screws to prevent loosening during firing. Blue Loctite 242 is used in most installations, but Blue 243 can also be used if 242 doesn't hold. Red 262 can be used in extreme cases. Blue 243 and Red 262 will require heat to be applied to the screws in order to soften the loctite to remove them.

- 1) Dry fitting the mounting screws. Degrease the mounting screws and mounting holes. Make sure that the mounting screws used match the mounting screw hole threads on the mount. Check that the mounting screw length is correct and that the screws go deep enough to properly secure the sight.
- 2) Remove the screws and install the sight. Make sure the sight fits all the way down flush to its mounting surface.
- 3) Apply Loctite to the the screw threads and carefully insert them through the sight and tighten using the sight tool, then torque to 15 in-lbs.
- 4) Wait 24 hrs for the thread locker to cure.

NOTE: Do Not Overtighten Mounting Screws! 15 in-lbs max torque.

Continued...

NOTE: DO NOT mount the sight with the front or back of the body tight against the mount or slide. There should be a minimum clearance of .025" between the front and back of the sight and the mount or slide cut. If the sight shows contact marks on the front or back, more clearance is required.

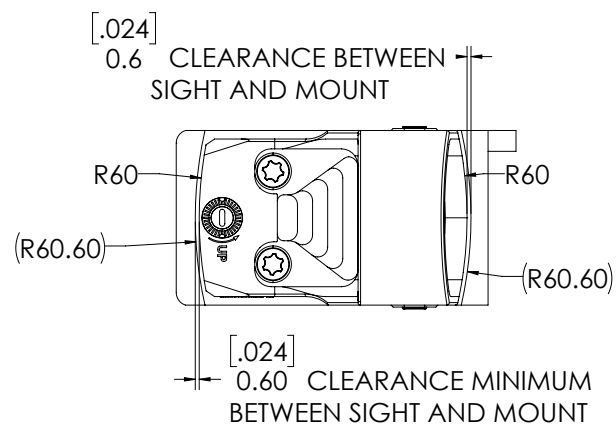

ZEROING

NOTE

The CRC Sight has an adjustment area of 113 in. wide x 127 in. tall at 100 yds (287.0 cm x 322.5 cm at 100 m).

- 1) Remove the sight cover.
- 2) Turn the sight on so the dot is visible.
- 3) Shoot a 3 shot group at a target 10 yards away to get on paper.
- 4) To adjust the elevation, insert the flat blade of the adjustment tool into the elevation screw. To raise the point of impact, turn the elevation screw counter-clockwise. To lower the point of impact, turn the elevation screw clockwise. (1 click = 1moa)
- 5) To adjust the windage, insert the flat blade of the adjustment tool into the windage screw. To move the point of impact left, turn the windage screw clockwise. To move the point of impact right, turn the windage screw counter-clockwise. (1 click = 1moa)
- 6) Adjust the windage and elevation so your group is centered and 2 to 3 inches low @ 10 yards.
- 7) Since the sight can only be zeroed for one distance, zero for the farthest distance you will shoot with this firearm.
- 8) Shoot a 3 shot group at the final distance you determined in step 7.
- 9) Adjust the windage and elevation until zero is achieved.
- 10) If zeroing is accurate, fire three more shots to confirm. If zeroing is not accurate, repeat steps 8 and 9 until zeroing is complete.

Adjustment Area @ 25 yds (Inches)

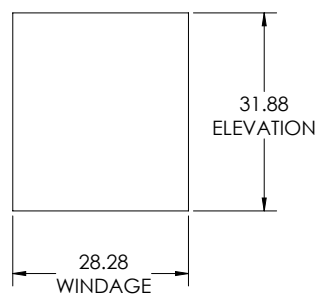

NOTE

After initial firing of 200 rounds, check to ensure that the mount and sight are secure. Tighten as necessary and check periodically (See Maintenance Procedures)

NOTE

If you run out of windage adjustment, loosen the mounting screws and reposition the sight to the right or left accordingly, then re-tighten and re-zero.

If you run out of elevation adjustment, it is possible the mount will need to be adjusted to angle the sight correctly.

MAINTENANCE

The CRC sight requires very little maintenance. Periodic cleaning of the lens and sight is encouraged, as well as checking the mounting screws to ensure that the sight is securely mounted.

SIGHT CLEANING PROCEDURE

The CRC sight can be cleaned using a soft cloth. Do not use abrasives or strong chemicals.

LENS CLEANING PROCEDURE (NOTE: A LensPen can also be used in place of this procedure)

CAUTION The lens can be scratched if dirt or debris is wiped across the lens.

- 1) Remove large particles from exposed lens surfaces by first blowing on the surfaces. Blow as much dust and dirt as possible from the exposed lens surfaces using compressed air.
 - 2) When all visible particles of dust and dirt have been removed, moisten a piece of lens tissue with lens cleaning solution, then gently wipe over the lens surface. Dry with clean lens tissue.
- NOTE: If the lens fogs over in cold weather, use a lens tissue to wipe clear.

MOUNTING CHECK PROCEDURE

Periodically check the sight to ensure that it is firmly mounted and there is no movement. If movement is detected, or mounting screws have loosened, remove the mounting screws, clean and re-apply loctite prior to re-installation.

CAUTION: Firing a weapon with a loose sight can cause damage to the weapon, the sight, and you! .

BATTERY REPLACEMENT PROCEDURE

- 1) Remove the mounting screws and remove the sight.
- 2) Using the flat end of the adjustment tool as shown, remove the battery.
- 3) Install the new battery and replace the sight by following the installation instructions on the previous page.



WARRANTY INFORMATION



For 30 years C-MORE sights have been in the hands of the hardest users: Military, Law Enforcement, and Competition Shooters; some who put over 150,000 rounds through a gun with our sight. We are the pioneers of open reflex sights for competition. We're the action shooters choice for 30 years because of our performance, reliability and customer service. Our competition record is unmatched.

We're proud to cover our products with a 30-year no hassle warranty from the date of manufacture. We warranty against all original defects in material or manufacturing, including electronics. This warranty is fully transferable.

We will repair or replace your genuine C-MORE product at no cost to you. If your product cannot be repaired, we will replace it with a product of equal or better physical condition in perfect working order. We pay return shipping back to you.

This warranty is void if the unit has been abused, disassembled, or modified/tampered with in any way from its original configuration. This warranty does not cover defects caused by normal wear and tear, improper handling, incorrect installation, accidents, alterations/modifications to the original configuration, repairs made by unauthorized parties, aftermarket accessories, or abnormal use.